

Contents

APPLICABILITY TABLE.....	2
1. INTRODUCTION	5
1.1. SCOPE.....	5
1.2. AUDIENCE.....	5
1.3. CONTACT INFORMATION, SUPPORT	5
1.4. DOCUMENT ORGANIZATION.....	6
1.5. TEXT CONVENTIONS	6
1.6. RELATED DOCUMENTS.....	7
1.7. DOCUMENT HISTORY	7
2. SIM INTERFACE OVERVIEW	8
3. ESD PROTECTION	10
3.1. ESD PROTECTION FOR SIM INTERFACE	10
3.2. ESD PROTECTION FOR USB INTERFACE.....	11
3.3. ESD PROTECTION FOR POWER SUPPLIES	12
4. CONFORMITY ASSESSMENT ISSUES	13
5. SAFETY RECOMMENDATIONS	14
6. LIST OF ACRONYMS.....	15



1.4. Document Organization

This document contains the following chapters:

[“Chapter 1: “Introduction”](#) provides a scope for this document, target audience, contact and support information, and text conventions.

[“Chapter 2: “SIM Interface Overview”](#) This section deals with the recommended schematics for the design of SIM interfaces on the application boards. ct.

[“Chapter 3: “ESD Protection”](#)

[“Chapter 5: “Conformity Assessment Issues”](#) provides some fundamental hints about the conformity assessment that the final application might need.

[“Chapter 6: “Safety Recommendation”](#) provides some safety recommendations that must be followed by the customer in the design of the application that makes use of the applying modules.

1.5. Text Conventions



Danger – This information MUST be followed or catastrophic equipment failure or bodily injury may occur.



Caution or Warning – Alerts the user to important points about integrating the module, if these points are not followed, the module and end user equipment may fail or malfunction.



Tip or Information – Provides advice and suggestions that may be useful when integrating the module.

All dates are in ISO 8601 format, i.e. YYYY-MM-DD.



2. SIM interface overview

This section deals with the recommended schematics for the design of SIM interfaces on the application boards. Figure 1 illustrates in particular how the application side should be designed, and what values the components should have.

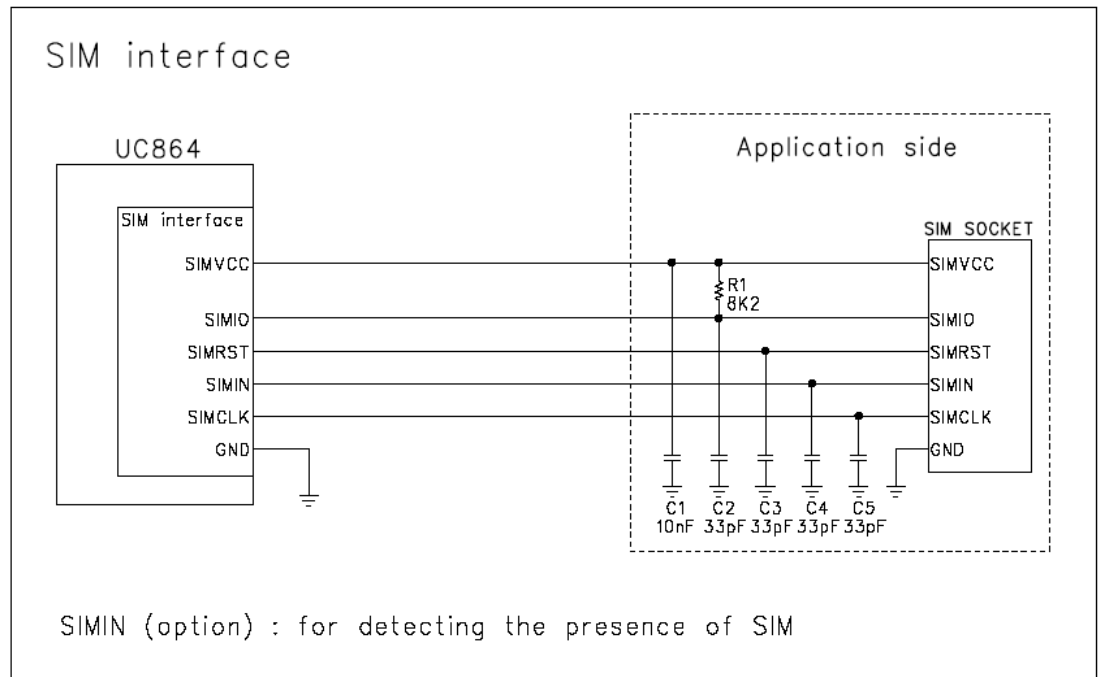

Figure 1



NOTICE:

Special attention should be paid to the value of Resistor R1. 3GPP specifications define that the rise time and the fall time of the IO signal shall not exceed 1 μ s. Resistor R1 is very closely related to the rise time and the fall time of the SIMIO signal. It can differ depending on the application board therefore, the customer point of view should be considered.



WARNING:

Do verify the appropriate specifications for your design. Refer to the following table.



3. ESD Protection



WARNING:

Do use TVS diodes or varistors to protect UC864-E/G/WDU from Electrostatic discharge.

3.1. ESD protection for SIM interface

The following schematics (figure 2) are recommended for the SIM interface.

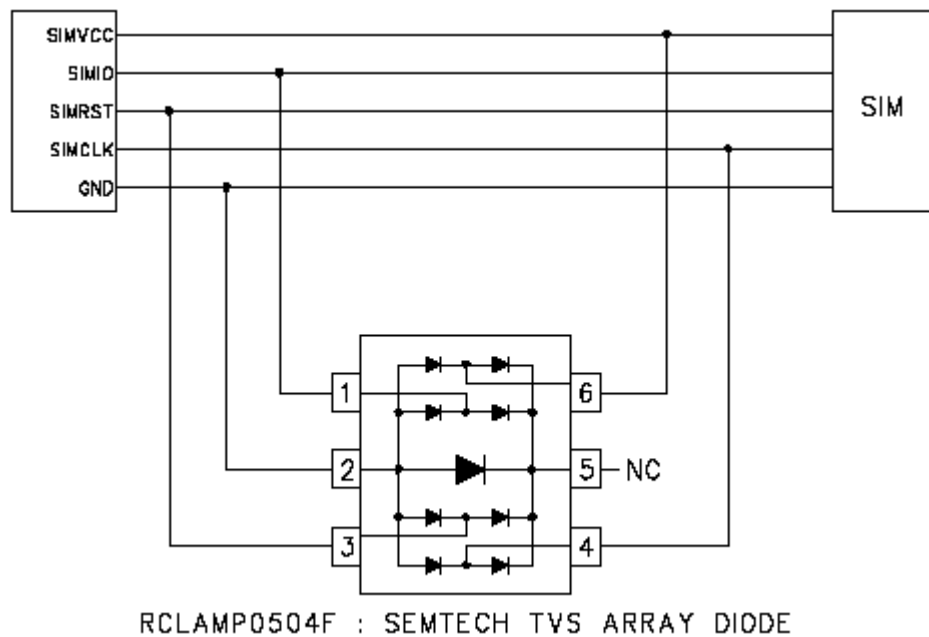

Figure 2

A single TVS diode or varistor can be used on the respective pins.



3.2. ESD protection for USB interface

The following schematics (figure 3) are recommended for USB interface.

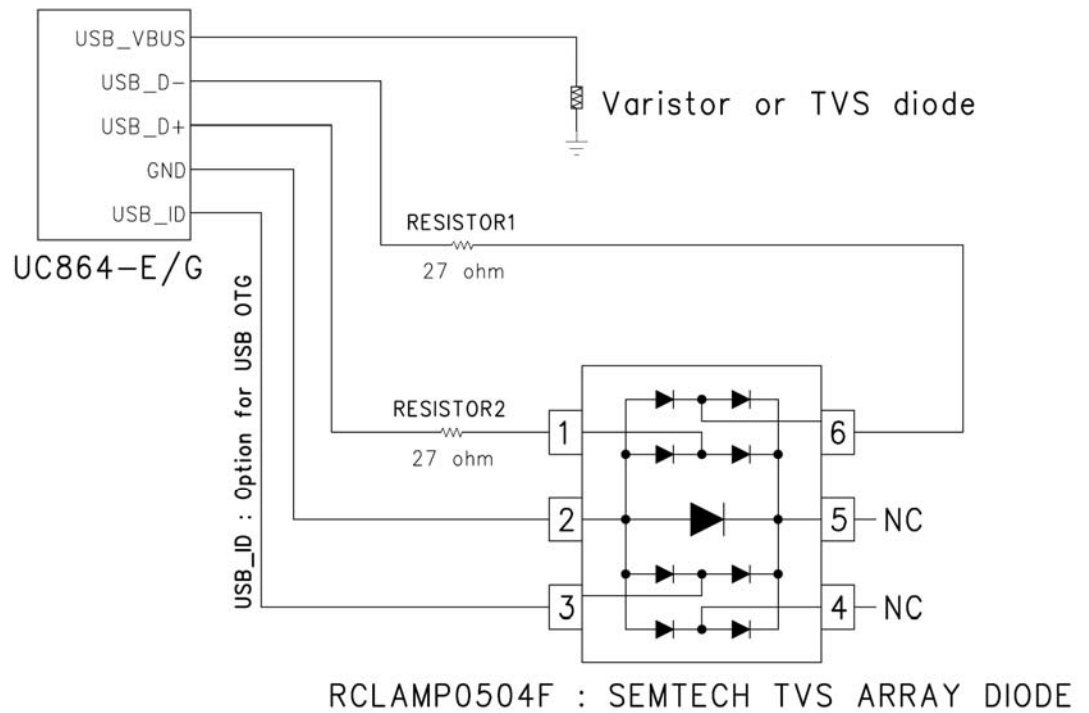

Figure 3

A single TVS diode or varistor can be used on the respective pins. Additionally, it is recommended that suitable resistors should be used to protect the USB D+/D- signal from ESD.



4. **Conformity assessment issues**

Please refer to the UC864-E/G/WD/WDU Product Description (80281ST10034a) for the conformity assessments.



5. Safety recommendations

Please refer to the UC864-E/G/WD/WDU Product Description (80281ST10034a) for information about safety recommendations.



